

**GRIGLIE DI RIPRESA IN ACCIAIO ZINCATO  
PASSO 50 MM**

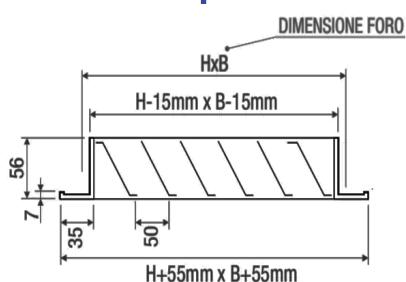

**DESCRIZIONE**

Griglie di ripresa costruite in robusto profilo di acciaio zincato. Le alette sono inclinate a 45° con passo 50 mm.

**CARATTERISTICHE**

**Materiale:** acciaio

**Finitura:** zincato

**Installazione:** fissaggio con viti frontali

**IMPIEGO**

Griglia adatta sia per la ripresa che per l'espulsione dell'aria. Si possono utilizzare sia all'interno che all'esterno degli edifici grazie al particolare profilo antipioggia.

**A RICHIESTA**

- Verniciatura nei colori RAL a scelta.

**NOTE**

Plenum zincato o isolato vedi modello EPB.

# EGRIZ5

## GRIGLIE DI RIPRESA IN ACCIAIO ZINCATO PASSO 50 MM

### DISEGNI

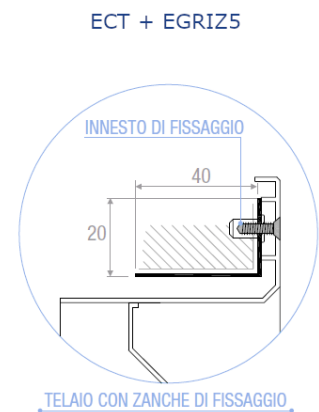
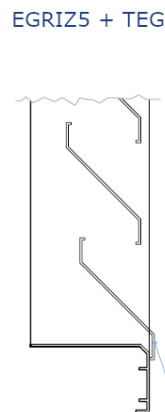
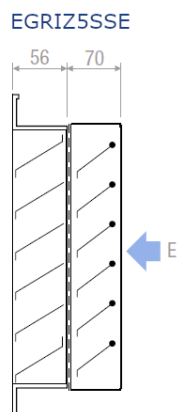
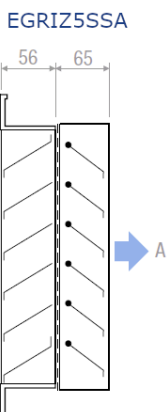
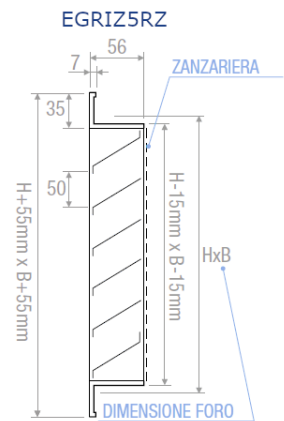
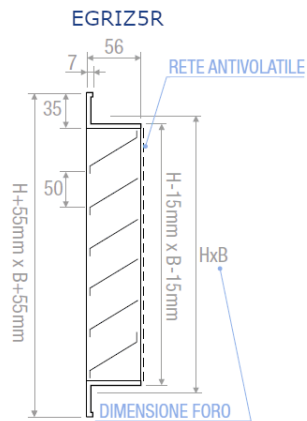
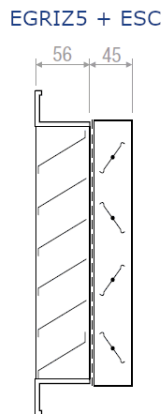
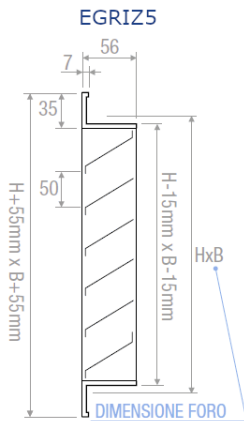

### TIPO DI FISSAGGIO

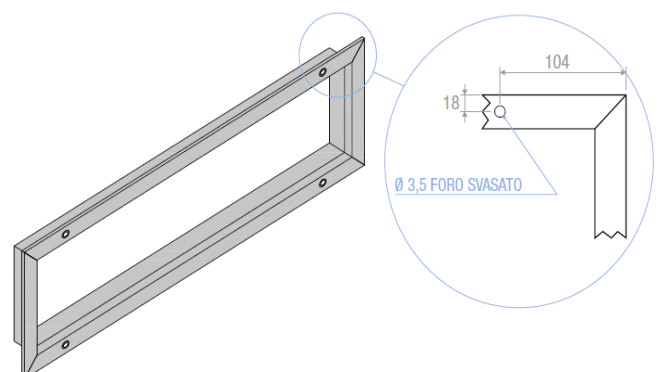
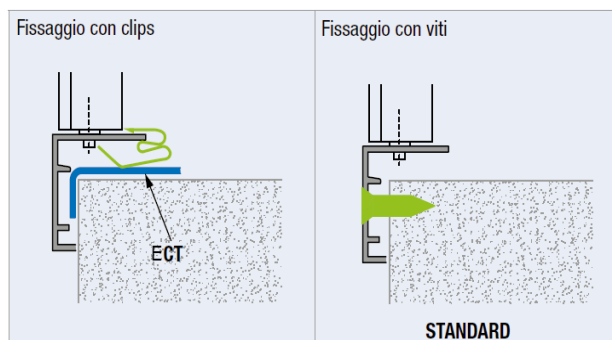

N.B: I valori indicati possono essere soggetti a modifiche senza preavviso

**GRIGLIE DI RIPRESA IN ACCIAIO ZINCATO  
PASSO 50 MM**

**DIAGRAMMA SCELTA RAPIDA**

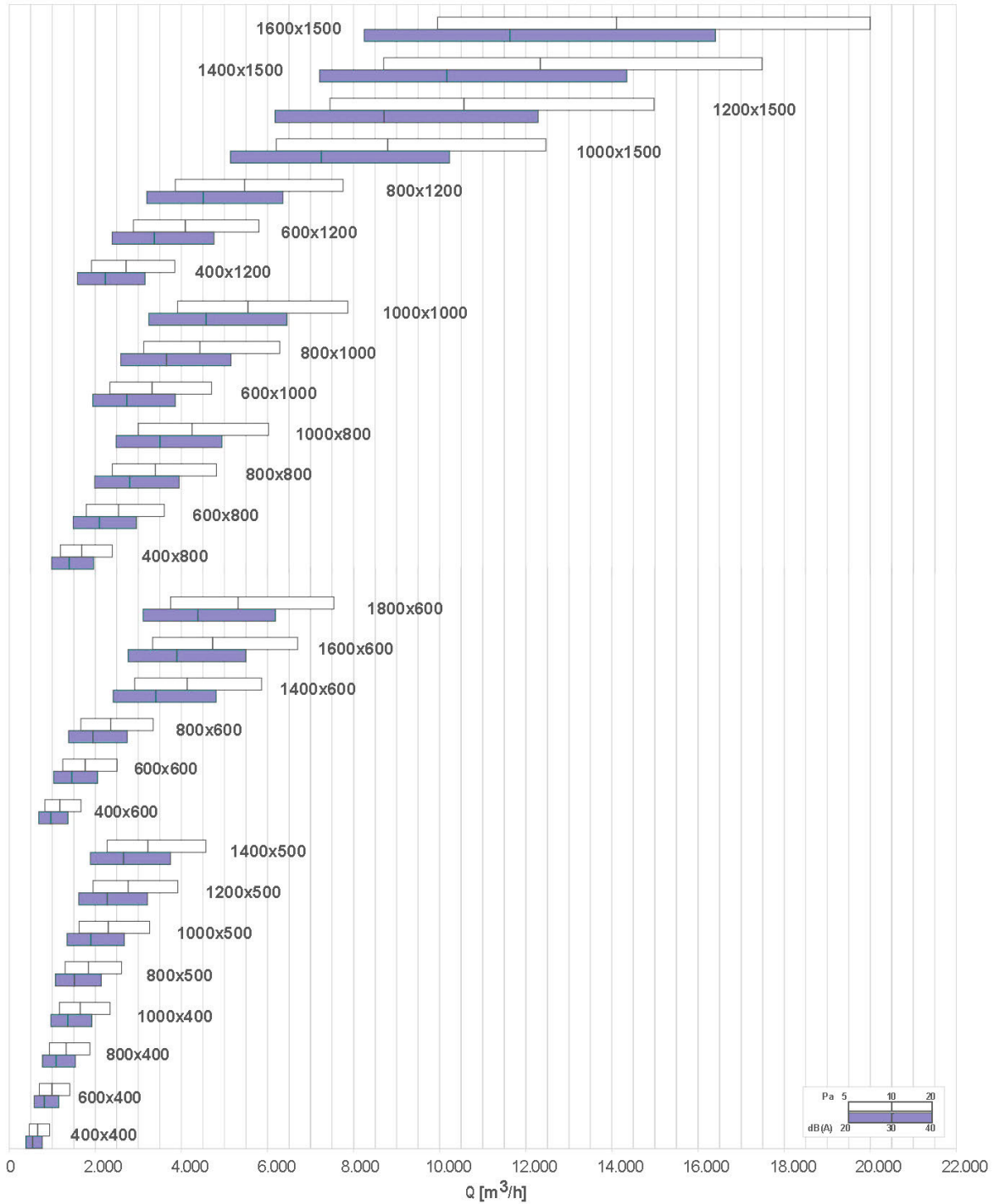

N.B: I valori indicati possono essere soggetti a modifiche senza preavviso

### DATI DI FUNZIONAMENTO EGRIZ5

Modello	Ak [m2]	Q [m3/h]		LWA [dB(A)]		Dpt [Pa]	
		min	max	min	max	min	max
400x400	0,0771	470	940	25	46	5	20
600x400	0,1153	700	1410	25	46	5	20
800x400	0,1535	930	1880	25	46	5	20
1000x400	0,1917	1170	2350	26	46	5	20
1200x400	0,2299	1400	2810	25	46	5	20
1400x400	0,2681	1630	3280	25	46	5	20
1600x400	0,3063	1870	3750	26	46	5	20
1800x400	0,3445	2100	4220	25	46	5	20
2000x400	0,3827	2330	4690	25	46	5	20
400x500	0,1068	650	1310	25	46	5	20
500x500	0,1335	810	1630	25	46	5	20
600x500	0,1602	980	1960	26	46	5	20
800x500	0,2135	1300	2610	25	46	5	20
1000x500	0,2669	1630	3270	26	46	5	20
1200x500	0,3203	1950	3920	25	46	5	20
1400x500	0,3736	2280	4570	26	46	5	20
1600x500	0,427	2600	5230	25	46	5	20
1800x500	0,4804	2930	5880	26	46	5	20
2000x500	0,5338	3250	6530	25	46	5	20
400x600	0,1365	830	1670	25	46	5	20
600x600	0,205	1250	2510	25	46	5	20
800x600	0,2735	1670	3350	26	46	5	20
1000x600	0,3421	2080	4190	25	46	5	20
1200x600	0,4106	2500	5030	25	46	5	20
1400x600	0,4792	2920	5870	25	46	5	20
1600x600	0,5477	3340	6700	25	46	5	20
1800x600	0,6162	3750	7540	25	46	5	20
2000x600	0,6848	4170	8380	25	46	5	20
400x800	0,1958	1190	2400	25	46	5	20
600x800	0,2947	1790	3610	25	46	5	20
800x800	0,3936	2400	4820	25	46	5	20
1000x800	0,4924	3000	6030	25	46	5	20
1200x800	0,5913	3600	7240	25	46	5	20
1400x800	0,6902	4200	8450	25	46	5	20

## GRIGLIE DI RIPRESA IN ACCIAIO ZINCATO PASSO 50 MM

DATI DI FUNZIONAMENTO EGRIZ5							
Modello	Ak [m2]	Q [m3/h]		LWA [dB(A)]		Dpt [Pa]	
		min	max	min	max	min	max
1600x800	0,789	4810	9660	25	46	5	20
1800x800	0,8879	5410	10870	25	46	5	20
2000x800	0,9868	6010	12080	25	46	5	20
400x1000	0,2552	1550	3120	25	46	5	20
600x1000	0,3844	2340	4710	25	46	5	20
800x1000	0,5136	3130	6290	25	46	5	20
1000x1000	0,6428	3910	7870	25	46	5	20
1200x1000	0,772	4700	9450	25	46	5	20
1400x1000	0,9012	5490	11030	25	46	5	20
1600x1000	1,0304	6270	12610	25	46	5	20
1800x1000	1,1596	7060	14200	25	46	5	20
2000x1000	1,2888	7850	15780	25	46	5	20
400x1200	0,3146	1920	3850	26	46	5	20
600x1200	0,4741	2890	5800	25	46	5	20
800x1200	0,6336	3860	7760	25	46	5	20
1000x1200	0,7932	4830	9710	25	46	5	20
1200x1200	0,9527	5800	11660	25	46	5	20
1400x1200	1,1122	6770	13620	25	46	5	20
1600x1200	1,2718	7740	15570	25	46	5	20
1800x1200	1,4313	8720	17520	25	46	5	20
2000x1200	1,5908	9690	19480	25	46	5	20
400x1500	0,4036	2460	4940	25	46	5	20
600x1500	0,6086	3710	7450	25	46	5	20
800x1500	0,8137	4960	9960	25	46	5	20
1000x1500	1,0187	6200	12470	25	46	5	20
1200x1500	1,2237	7450	14980	25	46	5	20
1400x1500	1,4288	8700	17490	25	46	5	20
1600x1500	1,6338	9950	20000	25	46	5	20
1800x1500	1,8388	11200	22510	25	46	5	20
2000x1500	2,0439	12450	25020	25	46	5	20
2000x1600	2,1949	13370	26870	25	46	5	20
2000x1800	2,4969	15210	30570	25	46	5	20
2000x2000	2,7989	17040	34260	25	46	5	20