

**SERRANDA A GHIGLIOTTINA MANUALE LEGGERA**



**DESCRIZIONE**

Le serrande a ghigliottina fino al  $\varnothing$  300 mm sono formate da due parti in acciaio stampato (spessore 1,2 o 1,5 mm) saldate tra loro e zincate. Il diaframma è in acciaio zincato stampato (spessore 1,2 o 1,5 mm). Standard con bordi.

**ESGML**  $\varnothing$  80÷300 mm: Manuale.

**ESGPL**  $\varnothing$  80÷300 mm: Pneumatica con cilindro.

Le serrande possono essere fornite con elettrovalvola da 110Vca - 220Vca - 24Vca - 24Vcc.

ELETTTR.  $\varnothing$  80÷300 mm: Elettrica con attuatore 220Vca o 24Vcc e carter di protezione. Velocità di chiusura 18 mm/s.

**ESGML**

**Serranda a Ghigliottina Manuale Leggera**

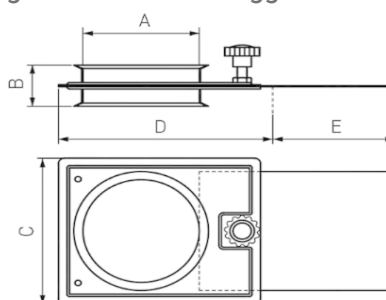

**ESGPL**

**Serranda a Ghigliottina Pneumatica Leggera**

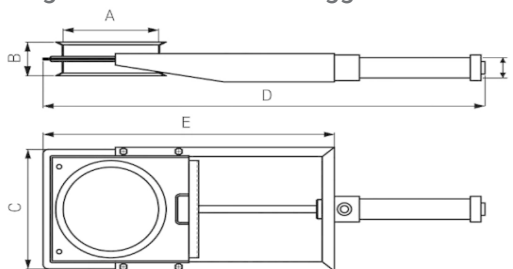

**ESGMLCL**

**Serranda a Ghigliottina Manuale Leggera Collo Lungo**

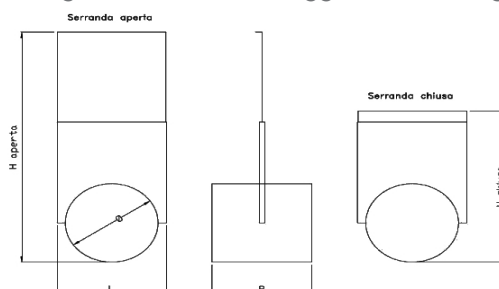

# ESGML

## SERRANDA A GHIGLIOTTINA MANUALE LEGGERA

DIMENSIONI ESGML					
A mm	B mm	C mm	D mm	E mm	Ø
80	38	116	150	90	-
100	38	136	180	110	-
120	50	156	210	130	-
125	50	156	215	135	-
140	50	176	240	150	-
150	50	186	250	160	-
160	50	189	270	170	-
180	50	216	300	190	-
200	50	236	330	210	-
220	65	260	365	230	-
225	65	260	365	230	-
250	65	295	400	260	-
280	65	325	450	290	-
300	65	345	480	310	-

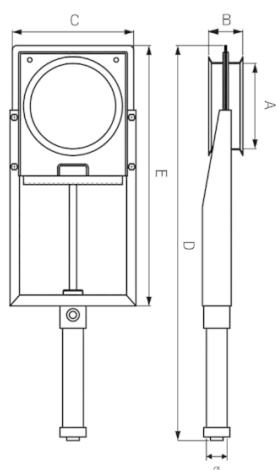
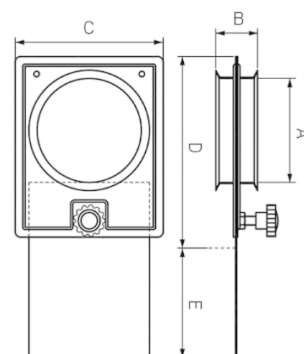

DIMENSIONI ESGPL					
A mm	B mm	C mm	D mm	E mm	Ø
Ø 80	38	116	380	245	20
Ø 100	38	136	450	290	20
Ø 120	50	156	510	330	27
Ø 125	50	156	510	330	27
Ø 140	50	176	570	370	27
Ø 150	50	186	600	390	27
Ø 160	50	196	630	415	27
Ø 180	50	220	690	450	27
Ø 200	50	236	750	490	27
Ø 220	65	260	840	550	27
Ø 225	65	260	840	550	27
Ø 250	65	295	920	610	27
Ø 280	65	325	1020	680	27
Ø 300	65	345	1070	710	27

DIMENSIONI ESGMLCL				
Ø	C	H Chiusa	H Aperta	P
80	105	170	240	150
100	125	220	310	150
120	145	250	360	150
140	165	270	410	150
150	175	295	435	150
180	205	320	490	150
200	225	360	550	150
220	245	390	600	150
250	275	435	675	150
280	305	455	725	150
300	325	475	765	150
320	345	490	800	150
350	375	515	855	150
400	425	560	950	150
450	475	735	1175	150
500	525	810	1300	150

